

AM-FM
STEREO RECEIVER

KR-9400

INSTRUCTION MANUAL



INTRODUCTION

Thank you for purchasing our receiver. Because we take great pride in the long tradition of quality components the name Kenwood receiver places you in a distinguished family of connoisseurs of superb high-fidelity sound reproduction.

The purpose of this manual is to acquaint you with the operating features of your new receiver. You will notice that in every detail of planning, engineering, styling, operating convenience, and adaptability, we have sought to anticipate your needs and desires.

We suggest that you read this manual carefully. Knowing how to set up your receiver, to the best advantage, will enhance your listening pleasure right from the start. You will also become aware of the ease with which you can adjust your receiver to meet your special requirements.

Turn the pages and become acquainted with the exciting features of your new receiver features that will remain new for endless hours of listening pleasure.

MAINTENANCE

CONCERNING TRANSISTORS

Transistors differ fundamentally from radio vacuum tubes and require special attention to ensure their full performance capabilities. Given proper care, transistors will provide years of practically troublefree performance.

- (a) Avoid locations subject to direct sunlight.
- (b) Avoid high or low temperature extremes.
- (c) Keep the receiver away from heat radiating sources.

PROTECTION CIRCUIT

The newly developed protection circuit is completely effective and prevents damage which may be caused by short-circuiting at the speaker terminals or the power output circuit of the receiver. When a short-circuit occurs, this protection circuit will function automatically to protect the power output transistors. If the power output transistor fails, this protection circuit will function automatically to protect the speakers.

NOTES

1. Units shipped to the U.S.A. and CANADA are designed to be operated with 120 volts AC only. Units shipped to the Scandinavian countries are designed to be operated with 220 volts AC only. Therefore the above units are not equipped with an AC Voltage Selector Switch so all reference to such a switch throughout this manual should be disregarded.
2. Units shipped to all other countries are equipped with an AC Voltage Selector Switch on the rear panel that is preset at the factory to the voltage generally available in the destination area.
It is very important, however, to check the Voltage Selector Switch setting and make sure that it corresponds to your line voltage before connection the power cord into an AC outlet. If the Voltage Selector requires re-setting, follow the directions outlined on page 13.

CONTENTS

FEATURES	3
INTERCONNECTING DIAGRAM	4
CONNECTING INSTRUCTIONS	5
CONTROLS AND THEIR FUNCTIONS	8
OPERATING INSTRUCTIONS	10
TROUBLE SHOOTING	14
SPECIFICATIONS	16

Dolby is a Trade Mark of Dolby Laboratories, Inc.

FEATURES

TUNER SECTION

1. 3-stage amplifier using MOS type FET assures excellent selectivity, sensitivity and S/N ratio as well as low cross modulation distortion and high spurious signal rejection.
2. The MPX section is equipped with a phase locked loop circuit for outstanding stereo separation and everlasting performance.
3. Adoption of LC type leakage carrier filter.
4. Capture ratio, IF stage selectivity and limiter effect are further improved with the use of IC and specially designed ceramic filter.
5. Accurate, Versatile Meter
Incoming signal level, FM multipath interference and FM frequency deviation can all be measured accurately with a very versatile meter located on the front panel.
6. A light emission diode is built in the dial pointer for easy tuning.
7. The dial scale has linear graduations (arranged at the same intervals) to make tuning easier. The effective length of the scale is as wide as 265 mm (10-7/16").

POWER AMPLIFIER SECTION

1. The main amplifier is especially designed for very low distortion factor and high reliability. It consists of a differential amplifier in the first stage and pure complementary symmetry OCL circuit directly coupled throughout the entire stage. The adoption of parallel push-pull circuit system offers a large 120 watts of power output per channel (20 Hz ~ 20 kHz).
2. The protection circuit using a DC detecting type, high sensitive relay and an ASO detecting type limiter, protects the speakers and power transistors against damage.

PRE-AMPLIFIER SECTION

1. The equalizer amplifier is a canteype, dual low noise operational amplifier which has very high stability and low distortion.
2. The tone control circuit is a 3-stage IC amplifier of NFB type employing the same operational amplifier. It features MID tone circuit and DEFEAT circuit that assures flat response and improved tonal quality.

... PLUS A WEALTH OF FEATURES AND CIRCUITS

1. DOLBY NR IN-OUT jacks
2. 4 channel adaptor jacks (in combination with DOLBY NR jacks)
3. SOUND INJECTION circuit
4. Two tape monitor circuits
5. Convenient tape monitor and tape dubbing switches
6. Connecting terminals for 3 pairs of speakers
7. 2 sets of PHONO jacks
8. FM DET OUT jack
9. Coaxial cable clamper
10. Click type VOLUME control

WARNING:

TO PREVENT FIRE OR SHOCK HAZARD,
DO NOT EXPOSE THIS APPLIANCE TO
RAIN OR MOISTURE.

INTERCONNECTING DIAGRAM

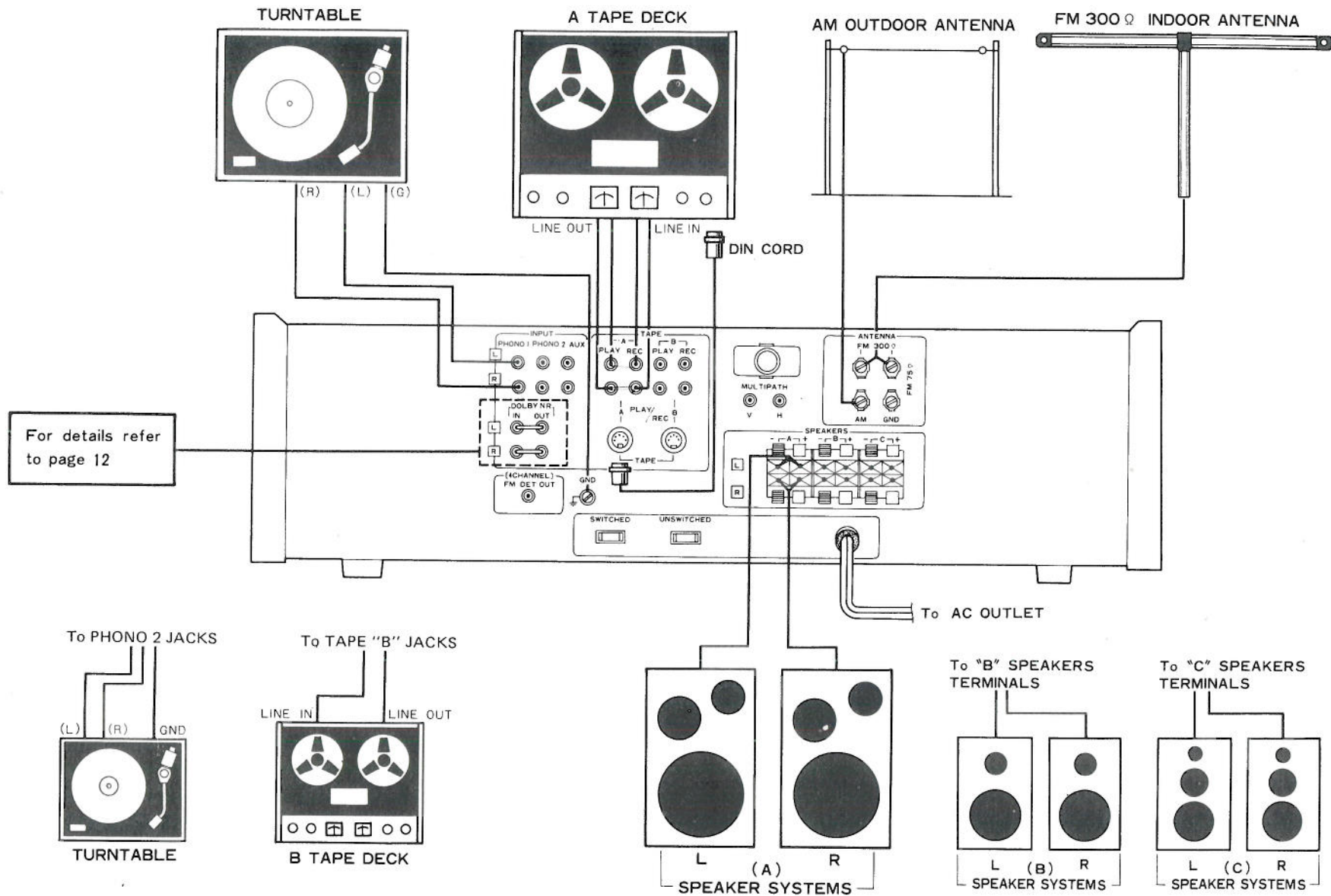

CONNECTING INSTRUCTIONS

SPEAKER CONNECTIONS AND SPEAKER SWITCH

In connecting only one set of speakers, connect the right speaker to right terminals and left speaker to left speaker terminals of "A" terminals. Should plus or minus of either right or left channel be reversely connected, sounds at the center section will be adversely affected by lack of bass sound. To connect a second set of speakers, connect right speaker to right speaker terminals and left speaker to left speaker terminals of "B" terminals. In the same manner, a third set of speakers can be connected to "C" terminals.

Sound cannot be heard when the SPEAKERS switch on the front panel is set to the A + B position, when only one pair of speaker system is used with connections made either to "A" SPEAKERS terminals or "B" terminals. When connecting the speaker leads to the SPEAKERS terminals, make sure that the bare wire strands at the ends of the speaker leads don't touch each other or adjacent terminal.

It is recommended that the tips of the speaker cord leads are soldered, or the strands of each individual lead twisted together to eliminate any possibility of short-circuits forming in the speaker connecting network.

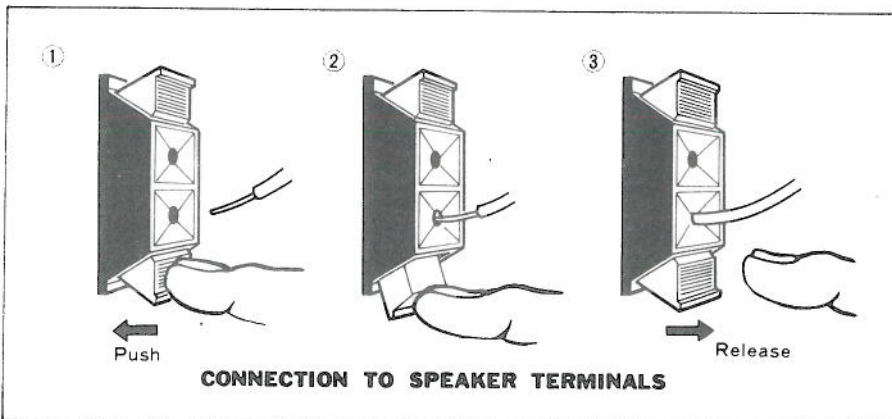

PHASING OF THE SPEAKERS

Speaker phasing can be determined in the following manner:

1. Set the SELECTOR switch to FM.
2. Set the MODE switch to MONO.
3. Tune in the desired station with the TUNING knob.
4. If the sound is coming directly from the front, the speakers are in phase. If the sound comes from both sides and there is a noticeable loss in low frequencies, the speakers are out of phase. In this case reverse the leads on one speaker.

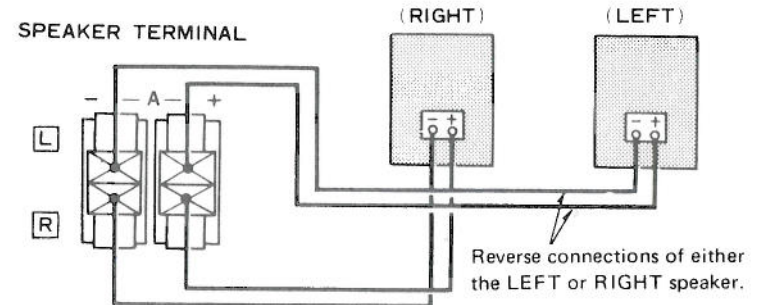

CONNECTING INSTRUCTIONS

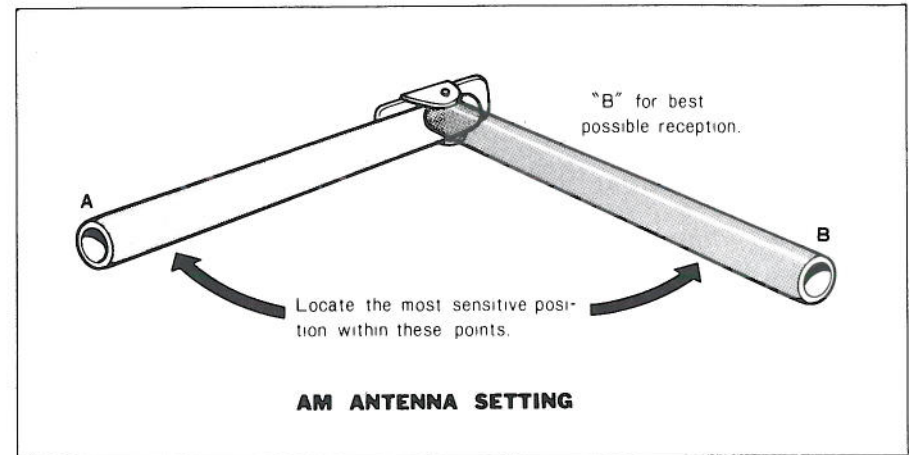
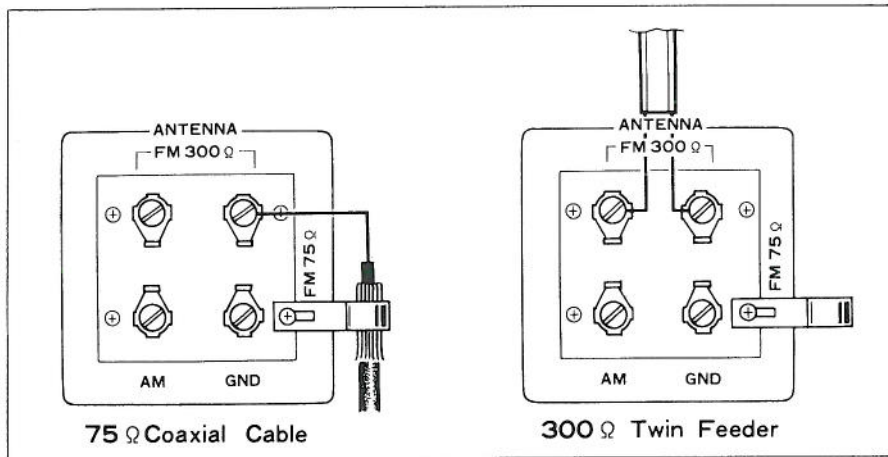

ANTENNA CONNECTIONS

Connecting The FM Antenna

Since FM broadcast signals travel along a straight, direct-line path, they become rather weak behind hills and buildings even in the vicinity of a broadcasting station. FM signals also become weak in areas distant from a station even though there may not be any obstruction to the direct-line path of the signal. Therefore, a good FM antenna should be installed in the most effective manner for best possible FM reception.

In areas near the FM station, where signals are strong, stretch the T-type indoor antenna that is supplied, to its maximum, and connect it to the FM 300 Ω ANTENNA terminals. This antenna should be carefully hung in the direction that provides best reception and clarity.

In areas subject to FM multipath interference such as locations behind hills or in the shadow of buildings, an outdoor FM antenna should be used. An outdoor FM antenna is also recommended for the reception of weak and distant FM stations. Connections should be made as follows: 300 ohm twin leads should be connected to the FM 300 Ω terminals, and 75 ohm coaxial cable to the FM 75 Ω terminals.

Connecting The AM Antenna

The AM ferrite loopstick antenna incorporated in this unit assures satisfactory reception of all local AM stations. Since the ferrite loopstick antenna has directional properties, you should adjust the antenna to the position which brings in the strongest signal.

In fringe areas or in locations surrounded by steel frame buildings where satisfactory reception cannot be obtained with the ferrite loopstick antenna, an AM outdoor antenna should be connected to the AM terminal.

NOTE:

AC cords, speaker leads, etc. which run adjacent to antenna leads, may interfere with reception. Keep them away as far as possible from the AM ferrite loopstick antenna.

TURNTABLE CONNECTIONS

The two shielded audio cables from your stereo turntable are normally terminated with phono plugs. Connect the left channel of the turntable to the "L" PHONO 1 input jack, and the right channel to the "R" PHONO 1 input jack.

If an additional turntable is used in order to operate two turntables, or if a turntable is used for reproduction of CD-4 discs,

CONNECTING INSTRUCTIONS

connect the left channel to the "L" PHONO 2 input jack, and the right channel to the "R" PHONO 2 input jack.

If the turntable has a grounding wire, connect it to this receiver's GND terminal to avoid hum.

TAPE DECK CONNECTIONS

Recording

A tape deck can be connected as follows for recording. Left channel input of the tape deck to TAPE A "L" REC jack. Right channel input of the tape deck to TAPE A "R" REC jack.

Playback

A tape deck can be connected as follows for playback. Left channel output of the tape deck to TAPE A "L" PLAY jack. Right channel output of the tape deck to TAPE A "R" PLAY jack.

DIN CONNECTOR (REC/PLAY CONNECTOR)

If your tape deck is equipped with a DIN connector, connect it to the REC/PLAY connector with a DIN connecting cord. A DIN connector enables recording and playback with this single cord.

NOTE:

When a DIN cord is used for connecting to the tape deck, the PLAY and REC jacks should not be used.

For highest fidelity recording and playback sound, however, it is recommended that the tape deck be connected to the PLAY and REC jacks instead of the DIN connector.

AUX (AUXILIARY INPUTS)

When a tuner, tape deck or other unit is connected here, it must have an output of at least 150 mV.

FM DET OUT JACK

The FM detector circuit output is made available here so that this receiver will be ready for 4-channel broadcasting developments in the future. When FM discrete 4-channel broadcasting becomes a reality, a simple demodulator connected here will enable you to fully enjoy this coming development.

DOLBY NR JACKS

If a DOLBY NR adaptor is connected to the receiver "DOLBY NR" jacks, not only can FM Dolby broadcasts be played back, but if a tape deck is connected to the adaptor itself, Dolby system recording and playback is possible. For further details refer to page 12.

MULTIPATH JACKS

Those who have general oscilloscope may connect it and actually see the incoming FM waveform, and turn the antenna to the setting which results in the least distorted waveform. See figure below.

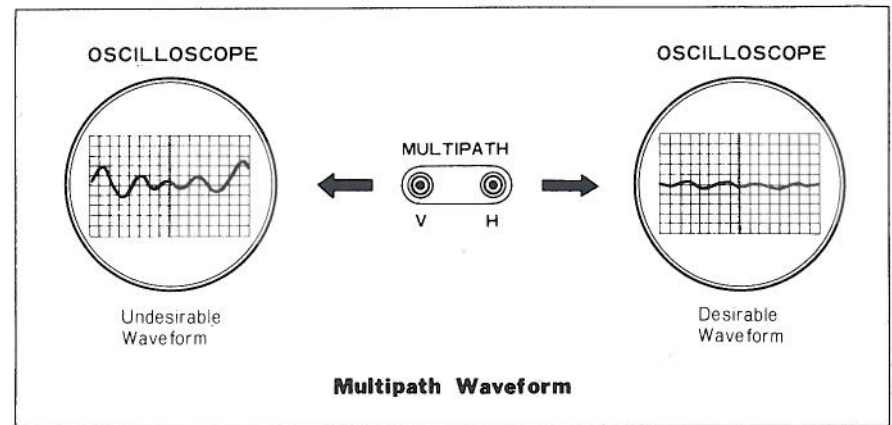

AC OUTLET

The AC outlets on the rear panel of the receiver may be used to supply power to other components such as a turntable, tape deck, etc.

1. SWITCHED outlet

This outlet is controlled by the POWER switch on the front panel. (The capacity is 100 watts maximum.)

2. UNSWITCHED outlet

This outlet is available at all times. (The total capacity is 200 watts maximum.)

CONTROLS AND THEIR FUNCTIONS

① POWER switch

ON — This position the receiver turns on.
OFF — This position the receiver turns off.

② SPEAKERS switch

OFF — This position silences all speakers for private headphone listening.
A — Activates speakers connected to the A SPEAKERS terminals on the rear panel.
B — Activates speakers connected to the B SPEAKERS terminals on the rear panel.
A+B — Activates simultaneously two sets of speaker systems connected to the A and B SPEAKERS terminals.
C — Activates speakers connected to the C SPEAKERS terminals on the rear panel.

③ PHONES jack

Plug a stereo headphone into this jack for private listening. The speakers are silenced when the SPEAKERS switch is set to OFF position.

④ TONE controls

BASS control

Turning it clockwise increases bass tone and counterclockwise decreases it. Tone is flat at zero position.

MID control

Turning it clockwise increases mid range tone and counterclockwise decreases it. Tone is flat at zero position.

TREBLE control

Turning it clockwise increases treble tone and counterclockwise decreases it. Tone is flat at zero position.

⑤ BALANCE control

This BALANCE control adjusts unequal volume from any program source in right and left channels. The left channel is accentuated when this adjuster is turned from center toward the left side, and conversely.

⑥ VOLUME control

The VOLUME control performs simultaneous adjustment of volumes in both channels (right and left). Set it to your own most satisfactory listening level.

⑦ INPUT SELECTOR switch

Switch positions and functions are as follows:

AM — For AM reception.

FM — For the reception of both FM monaural and stereo signals. Automatic switching operates between FM monaural and stereo sources.

When an FM stereo broadcast is tuned in, the STEREO indicator lights up.

PHONO 1 — In this position the turntable is available if connected to the PHONO 1 input jacks on the rear panel.

PHONO 2 — In this position the turntable is available if connected to the PHONO 2 input jacks on the rear panel.

MIC — In this position the microphone is available.

AUX — Selects source connected to the AUX jacks.

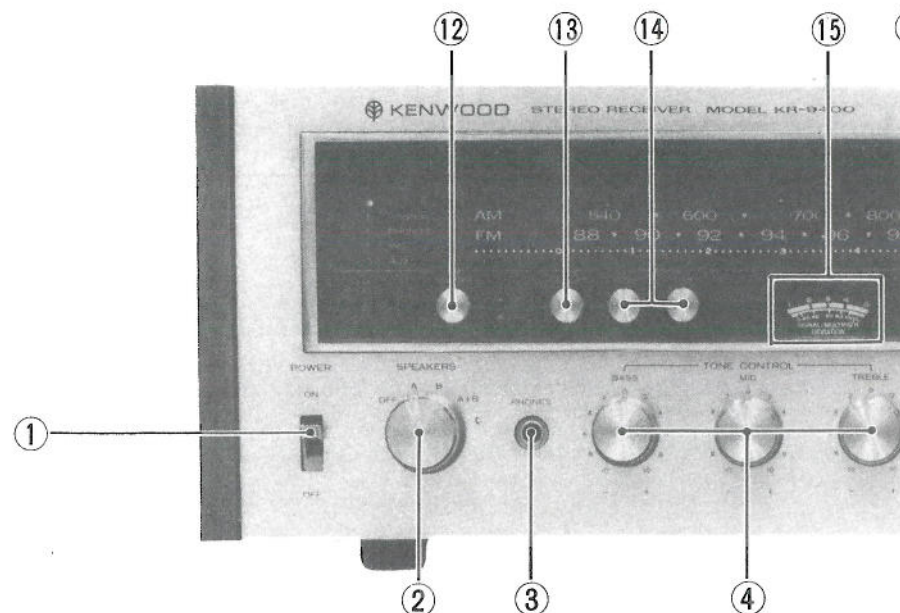

⑧ MODE switch

Switch positions and functions are as follows:

STEREO — This provides stereophonic reproduction of any stereo program source. The left channel is heard from the left speaker, and the right channel is heard from the right speaker.

REVERSE — This reverses positions of two speakers. The left channel is now heard from the right speaker, and the right channel from the left speaker.

MONO — Mixes left and right channels.

⑨ TAPE switches

MONITOR

Switch positions and functions are as follows:

SOURCE — The source signal is heard.

A — For monitoring a recording or for playback on a tape deck connected to the A TAPE jacks.

Sound recorded on the tape is heard.

B — For monitoring a recording or for playback on a tape deck connected to the B TAPE jacks.

Sound recorded on the tape is heard.

For further details refer to page 10,11.

DUBBING

Switch positions and functions are as follows:

DUBBING (A ► B) — For dubbing from a tape deck connected to the A TAPE jacks into a tape deck connected to the B TAPE jacks.

DUBBING (B ► A) — For dubbing from a B tape deck to A.

For further details refer to page 10,11.

CONTROLS AND THEIR FUNCTIONS

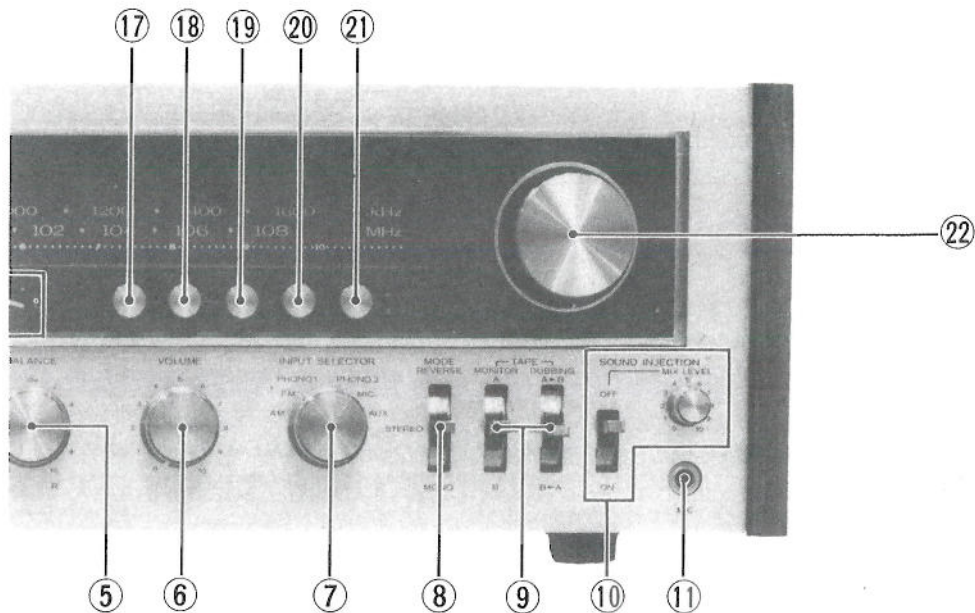

⑩ SOUND INJECTION

The SOUND INJECTION system is used to make mixing recording with your desired sound source (AM, FM, PHONO 1, PHONO 2, MIC or AUX) selected by the INPUT SELECTOR switch in the dubbing mode. The SOUND INJECTION switch must be set to the ON position. This switch should be turned OFF except when using the SOUND INJECTION.

⑪ MIC jack

This is a microphone jack for monophonic sound only.

⑫ FM MUTING switch

This switch silences interstation noise on the FM band, but it may also eliminate the signal of a weak and distant station along with the interstation noise. Therefore, set this switch to OFF (by pressing button release) in the reception of a weak and distant station.

⑬ TONE DEFEAT switch

This switch provides flat frequency response with tone control circuit deactivated. BASS, MID and TREBLE controls do not operate when this switch is set to ON.

⑭ LOW and HIGH FILTER switches

LOW FILTER — Setting this switch to on reduces low frequency noise such as turntable rumble, etc., which may interfere with program material. The low filters attenuate the low frequencies.

HIGH FILTER — Setting this switch to on reduces any high frequency noise such as tape hiss, record scratch, etc.

⑮ SIGNAL/MULTIPATH/DEVIATION meter

SIGNAL — Meter indicates signal strength during this function mode. Maximum deflection indicates best receiving condition.

MULTIPATH — When the MULTIPATH switch is pushed in during reception of an FM stereo broadcast this meter helps to detect FM multipath interference. Antenna direction should then be adjusted for maximum deflection which is the best position for FM reception with minimum distortion.

DEVIATION — When the DEVIATION switch is pushed in, this meter indicates the peak modulation ratio of the FM broadcast. For further details refer to page 10, "AM-FM RECEPTION".

⑯ TUNING meter

This meter is used for precise tuning to the center of an FM channel. Turn the tuning knob until the meter pointer is in the center of the meter scale. This provides maximum separation and minimal distortion.

⑰ MULTIPATH switch

The SIGNAL/MULTIPATH/DEVIATION meter functions as a multipath meter when the MULTIPATH switch is pushed in. Tune in an FM stereo station, depress the MULTIPATH switch and adjust the antenna direction for maximum deflection of the MULTIPATH meter. This indicates the best antenna position which offers the least multipath interference. This adjustment should be made only when an FM stereo broadcast is being received. The MULTIPATH meter does not function when an FM monaural or AM broadcast is being received.

⑱ DEVIATION SIGNAL switch

The SIGNAL/MULTIPATH/DEVIATION meter functions as a Deviation meter when the DEVIATION SIGNAL switch is pushed in. It functions only during reception of an FM broadcast.

⑲ FM DOLBY NR switch

When employing Dolby Noise Reduction Adaptor depress this FM DOLBY NR switch to ON to set DOLBYIZED FM DE-FMPHASIS. For further details refer to page 12.

⑳ AF MUTING switch

This switch reduces volume level momentarily as during a telephone call, etc. Output power is reduced 20 dB without touching the VOLUME control. Setting this switch to off returns volume level to original level.

㉑ LOUDNESS control

The LOUDNESS control boosts bass and treble tones at low listening levels. Our ears have less sensitivity to low and high frequencies at low listening levels and the LOUDNESS control compensates for this deficiency. This control should be switched off when listening at normal and high levels.

㉒ TUNING knob

The TUNING knob selects the desired AM or FM station signal. Adjust it for maximum deflection of the SIGNAL meter as you listen to the sound output from the speakers. For FM broadcasts also observe the TUNING meter to achieve accurate reception.

OPERATING INSTRUCTIONS

AM-FM RECEPTION

1. Set the INPUT SELECTOR switch to FM or AM.
2. Set the MODE switch to STEREO and the TAPE switch to SOURCE.
3. Adjust the VOLUME control to the desired listening level.
4. Use the BASS, MID, TREBLE, FILTERS and LOUDNESS controls to adjust sound as desired and to match the acoustic conditions of your room.

ABOUT DEVIATION

The Deviation Meter is very handy for "air-checking" FM reception conditions and for tape recording FM broadcasts. Used in conjunction with the VU meter of the tape deck, it helps to prevent distortion that is caused by excessive input recording levels.

The Deviation Meter indicates the frequency deviation of an FM broadcast and degree of modulation in terms of ± 75 kHz deviation at 100% modulation, and thus its swing pattern differs from that of the VU meter whose characteristics are closer to human hearing patterns and does not respond as well to pulse type and high frequency sounds. For ordinary music and sounds, best recording condition will be obtained if the recording level adjustment is made according to the average values of the two meters as shown in the table below.

It may be necessary to alter, to a certain extent, the level settings indicated in the table below depending on the type of tape used, also on the dynamic range handling capacity of the tape deck and/or the modulation degree of the broadcast being received.

Deviation Meter Indication (%) (KR-9400)	100	80	60	40	20
VU Meter Indication (VU) (TAPE DECK)	0	-2	-4.5	-8	-14

PHONO OPERATION

1. Two pairs of phono input jacks, PHONO 1 and PHONO 2, are provided to enable connections to two turntables. To reproduce the output of the turntable that is connected to PHONO 1 jacks, set the INPUT switch to PHONO 1. To reproduce the output of the turntable that is connected to PHONO 2 jacks, set the INPUT switch to PHONO 2.
2. Set the MODE switch to STEREO and the TAPE switch to SOURCE.
3. Adjust the VOLUME to the desired listening level.

4. Use the BASS, MID, TREBLE, FILTERS and LOUDNESS controls to adjust the sound to your preference and to the acoustic conditions of your room.

TAPE DECK OPERATION

Tape Monitoring

If you use the receiver with 3-head type tape decks, you can check the sound quality of the recording that is being made by momentarily comparing the recorded signal with the source signal as follows. Set the TAPE (MONITOR) switch to A (or B) to monitor the recorded sound. Set the TAPE (MONITOR) switch to SOURCE to monitor the source signal before it is recorded.

When Recording with One Tape Deck

Connect the tape deck to either the A TAPE jacks or B TAPE jacks on the rear panel.

Recording

1. Set the INPUT switch to the desired program source. Set the TAPE (DUBBING) switch to SOURCE. To monitor the recording, set the TAPE (MONITOR) switch to A or B, whichever side the tape deck is connected.
2. Recording level should be adjusted with the volume control of your tape deck.
3. Recording is not affected by the VOLUME, BASS, MID, TREBLE, FILTERS, LOUDNESS, etc., controls of the receiver.

When Recording with Two Tape Decks

Connect one tape deck to A TAPE jacks and the other to B TAPE jacks on the rear panel.

Recording

1. Set the INPUT switch to the desired program source.
2. Set the TAPE (DUBBING) switch to SOURCE.
3. Recordings can now be made into both tape decks simultaneously. To monitor these recordings, use the TAPE (MONITOR) switch as follows. Set it to A to monitor the recording being made with the tape deck connected to A TAPE jacks. Set it to B to monitor the recording being made in the

OPERATING INSTRUCTIONS

- tape recorder connected to B TAPE jacks.
- Recording levels should be adjusted exactly as described previously for single tape deck operation.

Playback

- The INPUT SELECTOR switch can be at any position.
- Set the TAPE (MONITOR) switch to the corresponding position (A or B).
- Adjust volume and tonal quality.

Dubbing

Tape recordings may be easily duplicated from one tape deck to another with minimal loss of quality by setting the TAPE switch to DUBBING (A ► B) or DUBBING (B ► A) as follows:

- The INPUT SELECTOR switch can be at any position.
- Set the TAPE switch to DUBBING (A ► B) when it is desired to copy recorded material on the tape deck A for re-recording on the tape deck B.

Set the TAPE switch to DUBBING (B ► A) when it is desired to copy a recording on the tape deck B for re-recording on the tape deck A.

The recording can be monitored.

- Operate both tape decks simultaneously.

THE THROUGH CIRCUIT

Moreover, this unit permits listening to other program sources such as FM broadcasts or records while tape dubbing.

- FM broadcasts can be tape recorded while simultaneously listening to records as follows:
 - Connect the Tuner to the "PLAY" jacks of the A TAPE group connector jacks on the rear panel of this unit, and the Tape Deck to the B TAPE group connectors.
 - Connect the Turntable to either PHONO 1 or PHONO 2 and set the INPUT switch to whichever connector that is used.
 - FM broadcasts can be recorded when the TAPE (DUBBING) switch is then set to A ► B and the Tape Deck operated in recording mode.

- Disc record sound is reproduced when the TAPE (MONITOR) switch is set to SOURCE.
 - FM broadcasts are reproduced when the TAPE (MONITOR) switch is set to A. The recorded sound of FM broadcasts are reproduced and can be monitored when the TAPE (MONITOR) switch is set to B.
- Disc record sound sources can be tape recorded while simultaneously listening to FM broadcasts as follows:
 - Connect the Tuner to the "PLAY" jacks of the A TAPE group connector jacks on the rear panel of this unit and the Tape Deck to the B TAPE group connectors.
 - Connect the Turntable to either PHONO 1 or Phono 2, and set the INPUT switch to whichever connector that is used.
 - Set the TAPE (MONITOR) switch to A and tune in FM broadcasts.
 - Set the TAPE (DUBBING) switch to SOURCE and the Tape Deck to recording mode. The sound from the disc record can then be recorded.
 - The FM broadcasts are reproduced when the TAPE (MONITOR) switch is then set to A. When it is set to SOURCE, the sound of the disc record will be reproduced. When it is set to B the tape recorded sound of the disc record can be monitored.

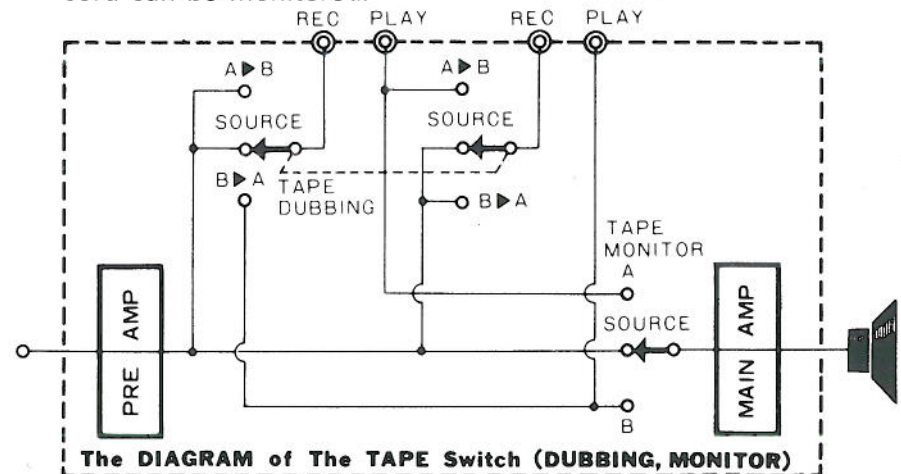

OPERATING INSTRUCTIONS

HOW TO USE THE DOLBY NR JACKS (1)

● Dolbyized FM Broadcasts Reception

1. Remove the attached jumper connector and connect the Dolby NR adaptor to the DOLBY NR IN-OUT jacks as shown in the figure below (A).
2. Set the INPUT SELECTOR switch to FM and tune in to a Dolbyized FM Broadcast.
3. Turn the FM DOLBY NR switch (on the front panel) to ON.

NOTE:

When using the DOLBY NR IN-OUT jacks do not use the attached jumper connector for other jacks. Keep it, because it must be plugged back into this jacks when it is not used.

● Dolby System Recording and Playback

Recording

1. Connect the Dolby adaptor output jacks to the tape deck LINE-INPUT jacks.
2. Select the program source of your choice with the INPUT SELECTOR switch.

3. Turn the FM DOLBY NR switch to **OFF**. (When recording Dolbyized FM Broadcasts depress the FM DOLBY NR switch to ON.)

Playback

1. Remove the attached jumper connector and connect the tape deck LINE-OUTPUT jacks to the input jacks of the Dolby adaptor.
2. Turn the FM DOLBY NR switch to **OFF** and playback your Dolbyized recordings. See figure below (B).

HOW TO USE THE DOLBY NR JACKS (2)

When it is desired to set up a 4 CHANNEL stereo system, remove the attached jumper connector and connect another decoder amplifier or demodulator to the DOLBY NR IN-OUT jacks at rear of the receiver. In this case, turn the FM DOLBY NR switch to **OFF**. It must be remembered, however, that a 4 CHANNEL program source is necessary for such operation. See figure below (C).

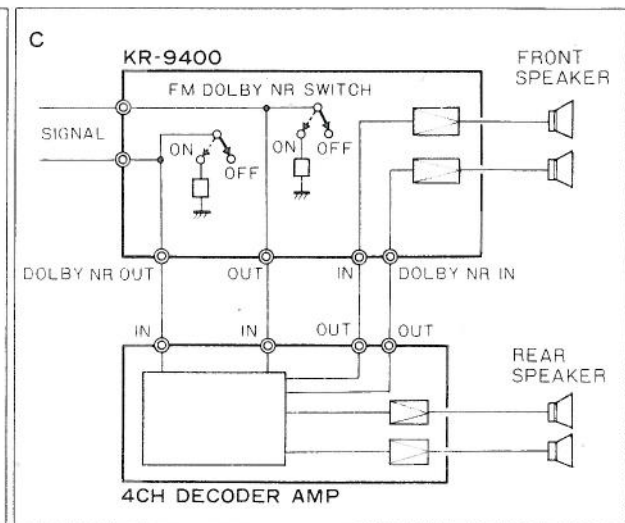
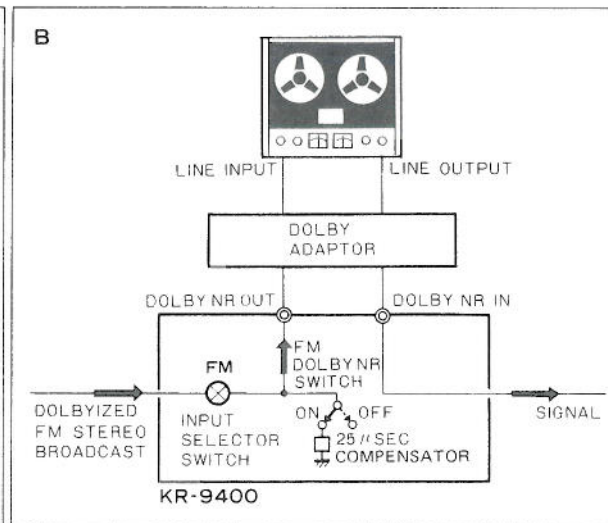
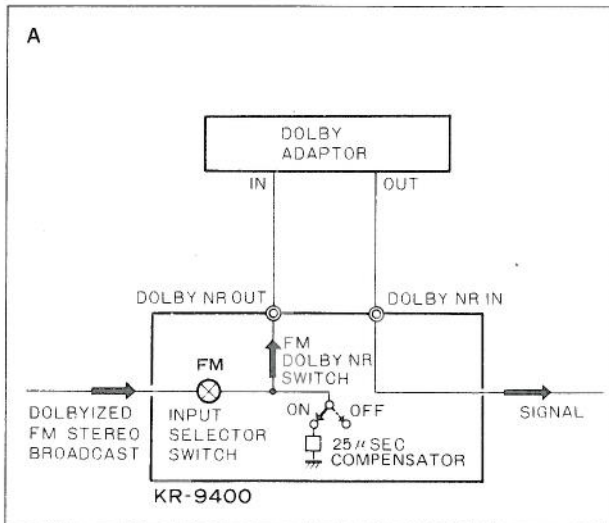

OPERATING INSTRUCTIONS

HOW TO USE THE SOUND INJECTION

The SOUND INJECTION system is used to make mixing recording with your desired sound source (AM, FM, PHONO 1, PHONO 2, MIC or AUX) selected by the INPUT SELECTOR in the dubbing mode.

In case of DUBBING "A ▶ B"

1. Select the source of your choice with the INPUT SELECTOR switch.
2. Set the SOUND INJECTION ON-OFF switch to ON.
3. Set tape deck A for reproduction and tape deck B for recording.
4. Adjust the INJECTION levels by using the MIX LEVEL control. To monitor the recording condition, set the TAPE MONITOR switch of the receiver to "B".
5. By switching back and forth between SOUND INJECTION ON and OFF, the two sounds can be arranged to make your desired tape library.

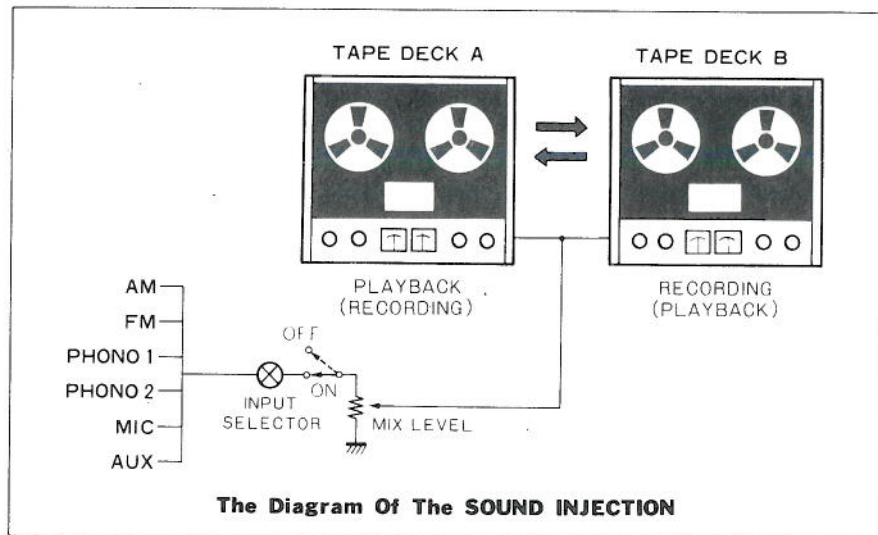

In case of DUBBING "B ▶ A"

In the same manner as described above, the sound from the tape deck B is mixed with the program source selected by the INPUT SELECTOR switch.

AC VOLTAGE SELECTION AND POWER FUSE

The KR-9400 operates on 110 - 120 volt 220 - 240 volt AC. The AC Voltage Selector Switch on the rear panel is set to the voltage that prevails in the area to which the receivers are shipped. Before operating this receivers, make sure that the position of the AC Voltage Selector Switch matches your line voltage. If not, it must be changed to the proper setting.

To change, first disconnect the AC line cord. Then remove the stopper plate and slide the AC Voltage Switch to the opposite side. Then reattach the stopper plate to the other side.

When the position of the AC Voltage Selector Switch is changed, it is also necessary to change the power fuse.

In such a case, consult a qualified serviceman.

NOTE:

Our warranty does not cover damage caused by excessive line voltage due to improper setting of the AC Voltage Selector Switch.

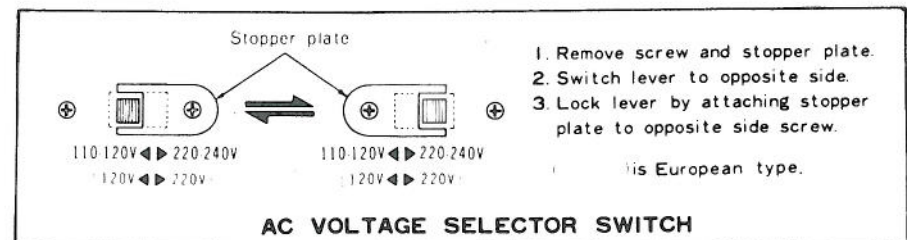

TROUBLE SHOOTING

In initially installing this receiver, improper connections may result in one of the following indications of trouble. Their possible causes and corrective measures are listed below to facilitate installation.

INDICATIONS

Occurs Only During AM Reception	Cause	Correction
Continuous low frequency buzz. Most noticeable at night on weak signal stations.	Interference from electrical appliances or atmospherics.	Erecting a 10 meter outdoor antenna and securing good ground conditions should reduce interference considerably. Complete elimination is difficult.
Continuous high frequency whine which increases at night.	TV interference. 10 kHz beat interference from adjacent AM station.	Turn TV off. (Neighboring TV set may also be caused.) Impossible to eliminate from receiver side. This is one disadvantage of the AM broadcast system. Use High Filter to cut off high frequency interference.
Intermittent buzzing or sharp crackling noise.	Lightening interference. Interference from fluorescent lamps. AC Plug Connection.	Occurs when lamps are on and cannot be helped. Try reversing AC plug connections. Occurs only on certain stations due to high voltage power line and cannot be helped in many areas.
Interference from amateur stations.	Called BCI, this interference results from neighboring amateur stations. (Also occurs on FM.)	Consult interfering station operator or authorities concerned.
Occurs Only During FM Reception	Cause	Correction
Continuous hiss or buzzing interference with broadcast. Becomes louder during stereo.	Incoming signal too weak at ANT terminal.	Erect outdoor FM antenna if only indoor T-type is used. A 5 or 7 element antenna is necessary if you are located at a considerable distance from the broadcasting station.
Occasional sharp buzzing or crackling noise.	Automobile ignition-noise. More noticeable on weak signals.	Erect outdoor FM antenna as far away from roads as practicable.
Weak right channel response when listening to LEFT only test FM Stereo broadcast.	Called crosstalk, a very slight reponse is normal.	It is not a sign of trouble. It cannot be reduced to zero.
FM Automatic Circuit fails to respond to stereo broadcast.	Incoming signal is exceptionally weak.	Erect an FM outdoor antenna.

INDICATIONS

During AM, FM or Record Playback	Cause	Correction
No pilot lamp indication, no sound although AC is switched ON.	Poor AC plug connection. Blown fuse.	Check plug contact Replace fuse. If it blows again, trouble must be corrected.
No sound from LEFT and RIGHT.	SPEAKERS switch set to A + B position. Speaker cords disconnected. SPEAKERS switched to OFF. Volume Control (extreme left). TAPE MON switch at A or B position	A-B groups of speakers are required in this case for response from both sides. Check connections from amp output to speakers. SPEAKERS switch should be switched to OFF only when using stereo headphones. Set to appropriate volume level. Always set to SOURCE except when using tape decks.
Sound only from one side.	Poor speaker cord connections. BALANCE control set to one extreme or other.	Check amp. output and speakers connections. Adjust BALANCE control.
Noise when AC is switched ON or when volume is adjusted immediately after.	Insufficient circuit warmup.	Allow 2 ~ 3 second interval after switching AC ON, before manipulating volume control.
Unbalance results when volume is lowered.	LEFT RIGHT resistor values unbalanced.	Adjust BALANCE control.
Difference in volume level of radio and phono.	Difference in received signal and phono output levels.	Set to appropriate volume level.
During Phono Record Playbacks Only	Cause	Correction
No sound from LEFT and RIGHT, or sound only from one side.	Turntable output disconnected.	See that turntable output cord is firmly plugged into amp. input.
Loud hum drowns out sound.	Poor turntable output cord prong connections.	See that turntable output cord is firmly plugged into amp. input.
Sound audible but background hum occurs.	Turntable output cord picking up hum from AC cord. Turntable not grounded.	Keep turntable output cord away from AC cords. Choose cord paths which keep hum at a minimum. Twist LEFT RIGHT turntable output cords together. Reverse turntable AC plug connections. Connect ground wire to GND terminal.
Sound audible but continuous background buzz interferes.	TV signal picked up by Turntable output cord. Frequency occurs near TV transmitting antenna.	Route turntable cord so that hum is minimized.
Howling noise occurs when volume is raised or bass response is increased.	Speaker vibrations induce feedback in Pickup.	Increase distance between turntable and speakers. Choose speaker locations carefully. Remember, loose flooring induces howling.

SPECIFICATIONS

FM TUNER SECTION

FM Frequency Range	88 MHz to 108 MHz 87.5 MHz to 108 MHz (FTZ approved)
Usable Sensitivity (IHF)	1.7 μ V
Harmonic Distortion	0.3% Mono (at 400 Hz 100% modulation) 0.5% Stereo (at 400 Hz 100% modulation)
Signal to Noise Ratio	72 dB at 1 mV input
Image Rejection	80 dB
Selectivity (IHF ALT Channel)	80 dB
IF Rejection	100 dB
Spurious Signal Rejection	90 dB
AM Suppression	55 dB
Capture Ratio	1.3 dB
Stereo Separation	45 dB at 1,000 Hz 35 dB at 10,000 Hz
Sub Carrier Suppression	62 dB
Antenna Impedance	300 ohms Balanced & 75 ohms unbalanced

AM TUNER SECTION

Usable Sensitivity (IHF)	15 μ V
Signal to Noise Ratio	50 dB at 1 mV input
Image Rejection	70 dB
Selectivity (IHF)	35 dB
IF Rejection	70 dB

POWER-AMPLIFIER SECTION

Power Output	120 watts per channel, minimum RMS at 8 ohms from 20 Hz to 20 kHz with no more than 0.1% Total Harmonic Distortion
Both Channels Driven	125 watts per channel into 8 ohms at 1,000 Hz 150 watts per channel into 4 ohms at 1,000 Hz
Dynamic Power Output	310 watts into 8 ohms 480 watts into 4 ohms
Total Harmonic Distortion	0.02% at 1/2 rated power into 8 ohms at 1,000 Hz
Intermodulation Distortion (60 Hz : 7 kHz = 4 : 1)	0.1% at rated power into 8 ohms 0.02% at 1/2 rated power into 8 ohms
Power Bandwidth	5 Hz - 40,000 Hz
Damping Factor	50 at 8 ohms
Speaker Impedance	Accept 4 ohms to 16 ohms

PRE-AMPLIFIER SECTION

Input Sensitivity & Impedance	
Phono 1	2.5 mV. 50 K ohms
Phono 2	2.5 mV. 50 K ohms
AUX	150 mV. 50 K ohms
Tape Play A, B	150 mV. 50 K ohms
Mic	2.5 mV. 50 K ohms
Maximum Input Voltage (rms)	
Phono 1, 2	150 mV. T.H.D. 0.1% at 1,000 Hz
Signal to Noise Ratio (IHF A CURVE)	
Phono 1, 2	70 dB
AUX	93 dB
Tape Play A, B	93 dB
Mic	65 dB
Frequency Response	
Phono 1, 2	RIAA Standard curve \pm 0.3 dB
AUX, Tape Play	20 Hz - 35,000 Hz \pm 0 dB -1
Tone Controls	
Bass	\pm 10 dB at 100 Hz
Mid	\pm 10 dB at 800 Hz
Treble	\pm 10 dB at 10,000 Hz
Loudness Control (-30 dB)	+8 dB at 100 Hz, +5 dB at 10,000 Hz
Low Filter 100 Hz	12 dB/oct
High Filter 7,000 Hz	12 dB/oct

GENERAL

Switches	
Speaker Selector	OFF, A, B, A + B, C,
Input Selector	AM-FM-PHONO 1-PHONO 2-MIC-AUX
Mode	REVERSE-STEREO-MONO
Tape Monitor	MONITOR (A, B), DUBBING (A \blacktriangleright B), (B \blacktriangleright A)
Others	LOUDNESS, AF MUTING, FM DOLBY NR (DE-EMPHASIS SELECTOR), DEVIATION, MULTIPATH, HIGH FILTER, LOW FILTER, FM MUTING, SOUND INJECTION, TONE DEFEAT, INJECTION LEVEL
AC Outlet	Switched 1, Unswitched 1
Power Consumption	415 watts at full power 60 watts at no signal
Dimensions	W 21-15/16" (557mm), H 6-9/16 (166mm), D 15-9/16" (395mm)
Weight	45.4 lbs (20.6 kg)

NOTE: Any of the specifications given here may be changed or modified without notice.